



EXQUISITE BRAND IMAGE

Lumaire Textile



3 YEARS WARRANTY

APPLICATIONS

- POS Display
- Signage
- Advertising design
- Trade fairs
- Retail
- Interior design
- Hotels

FEATURES

- Frame thickness is just 23 mm for S.S, and 50 mm for D.S.
- Brightness up to 11000lx on the surface depending on size
- Single sided and double sided
- Low power consumption
- Wide application possibilities, from interior design to signage

TECHNICAL SPECIFICATIONS

MAIN MATERIAL
Clear acrylic (PMMA)

LUMINOUS EFFICIENCY
up to 160lm/W

MAXIMUM SIZE
2450 x 1250 mm

POWER SUPPLY
DC 12V / 24V / CC Adaptor

LIGHT TRANSMISSION
93%

IP RATING
IP 20

LIFETIME
> 50,000 hours

WORKING VOLTAGE
DC 12V / DC 24V / DC CC

FRAME THICKNESS
23 mm S.S, 50 mm D.S.

COLOUR TEMPERATURE
3000K 4000K 5000K 6500K

OPERATING TEMPERATURE
-30°C ~ + 40°C

INPUT VOLTAGE
AC 100 ~ 240V 50/60Hz

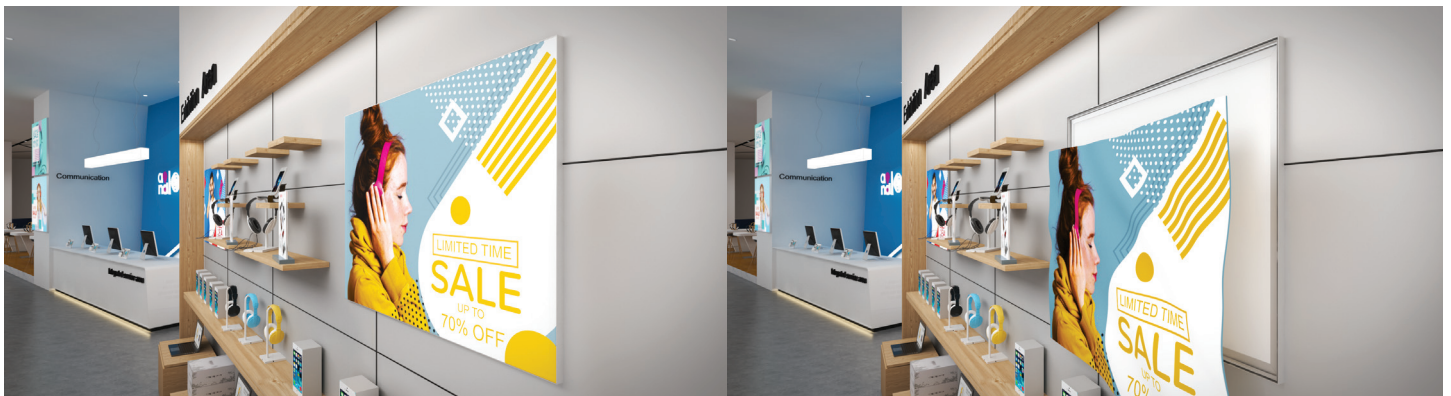

TECHNICAL DRAWING

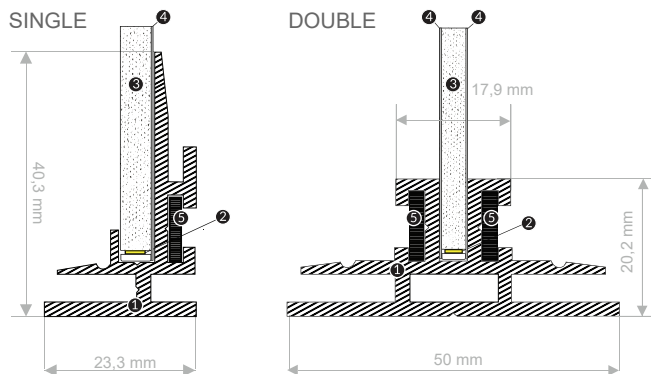

SINGLE

1. Frame basic
2. LED bar
3. Acrylic sheet
4. Reflector
5. Brackets

DOUBLE

1. Frame basic
2. LED bar
3. Acrylic sheet
4. Diffuser
5. Brackets

PACKAGE INCLUDES

Power supply (Mean well GST series power supply)
 Optional: wall mounting kit

MOUNTING INFORMATION

SIZE (Y), mm	→	←	CENTER	→	←
200-700	80 mm	80 mm			
700-1000	150 mm	150 mm			
1000-1500	150 mm	150 mm	•		
1500-2000	150 mm	150 mm		•	700 mm 700 mm
2000-2450	150 mm	150 mm		•	700 mm 700 mm

Holes will be drilled on both long sides (panel size (Y))
 → Pre drilled hole position from the left edge ← Pre drilled hole position from the right edge

